

TAPCO PRO-FILER™

SQUARING & MEASURING GAUGE

For use with Tapco Pro-II, Pro-III, Pro 2000 and Max II Port-O-Benders

ASSEMBLY INSTRUCTIONS

Pro-Filer and Pro-Filer 2000 Models

Always wear safety glasses when using power tools.

TOOLS NEEDED:

- A drill with a 13/64" bit
- Phillips screw drier
- 3/8" socket wrench
- 3/4" open end wrench
- Tape rule and pencil

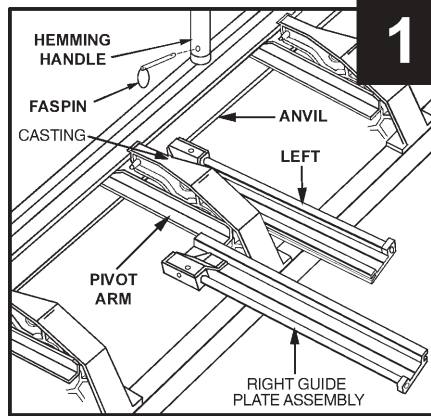

First for more room to install components, unlock bender, remove faspin and detach the hemming handle. Locate center-most casting on bender. Slide left and right guide plate assemblies onto pivot arms until butted tightly against anvil. From underneath the plates, tighten all 4 knurled screws.

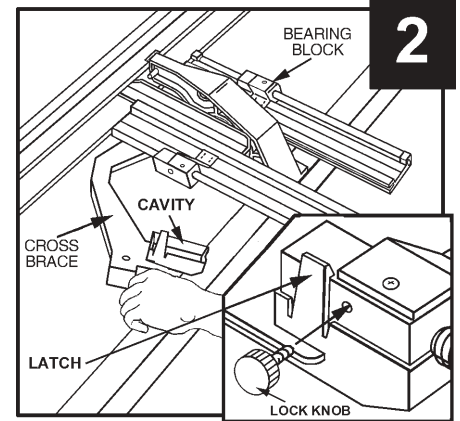

Position cross-brace under guide plates and align bearing blocks with cavities located at each end of cross-brace. Fit each block into cavity until latch snaps over top of the bearing blocks. Draw bearing blocks toward rear of bender and tighten lock knobs (to give you more room to work).

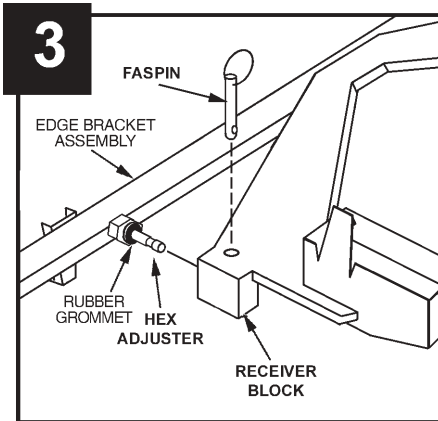

Take edge bracket assembly and insert hex adjuster pins into receiver blocks located at each end of the cross-brace. Once both adjusters are in place, lock them down by inserting both faspins through holes located in the top of the receiver blocks.

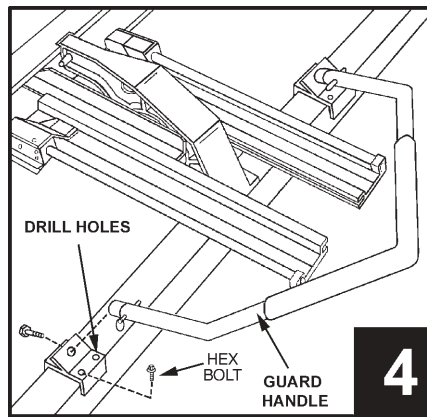

To protect the Pro-Filer, center the guard handle assembly around the Pro-Filer as shown. Drill holes using a 13/64 drill bit into your benders back rail. Install self-tapping hex bolts (3/4"), using a 3/8 socket wrench.

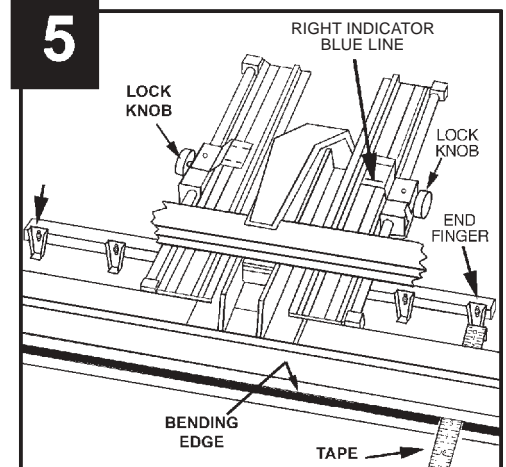

Reinstall the hemming handle and open the bender jaws. Retract right indicator blue line to 8" mark on tape ruler and lock in place with lock knob. Insert tape measure against each end finger and measure distance to the bending edge. If tape reads 8", the Pro-Filer is calibrated. If tape does not read 8", see step 6 below.

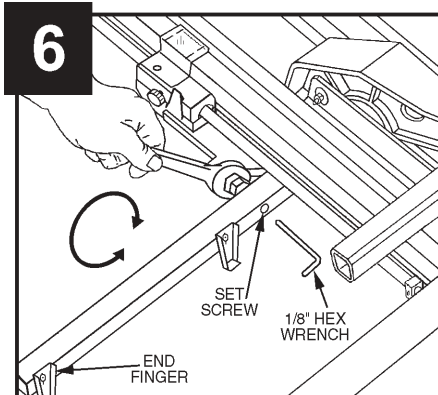

To calibrate Pro-Filer, open bender jaws and again insert tape measure to each end finger. If the tape reads less than 8" at the bending edge, loosen set screw and rotate hex adjuster clockwise using a 1/2" open end wrench until tape reads 8". Retighten set screws. If tape measure reads more than 8", loosen set screw and rotate hex adjuster counterclockwise until tape reads 8", retighten set screw.

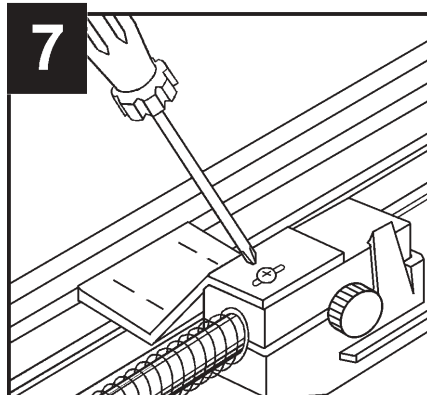

After the end fingers are calibrated 8" from the bending edge, check each indicator blue line for alignment to the 8" marks on the built-in tape rulers. If blue lines are not set to 8", loosen set screws on guide lens and position blue lines to the 8" marks and retighten screws.

Read all instructions carefully before use

CONTENTS PAGE

Pro-Filer Set-Up	1
Making Templates	2
Operations	3
Parts List	4

U.S. and Foreign Patents Pending

FORMING A PRO-FILER STRIP TEMPLATE

NEEDED: A PENCIL, PRO-FILER STRIPS AND A HAND BENDER (optional)

Note" Read instructions thoroughly before starting.

JOB INFORMATION FOR FUTURE REFERENCE

	Contractor _____	Job Name _____	Coil Brand _____	Tapco International Plymouth, MI USA (734) 451-8272 Part #WS01
	Phone _____	Piece Number _____	Coil Color _____	



Before you get started:

The minimum measurement the Pro-Filer will register is 2 inches. In situations where a particular bend will not register, pre-mark bending point directly onto the material. Align marks to the bending edge of the bender and make bend.

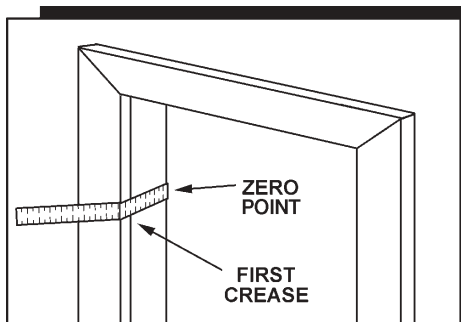

1 Align zero point on the Pro-Filer Strip with the starting point of the trim piece. Bend a crease in the Strip at the first bending point in the trim work. Use the ruled side to represent the finish side of the material. Use your hand pressure to crease the strips or use a hand bender.

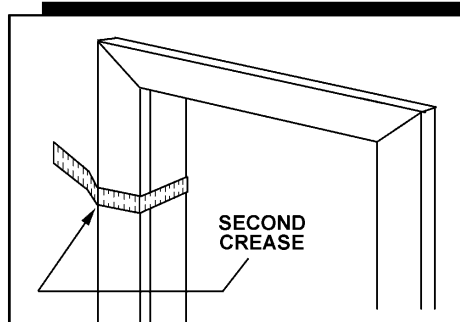

2 Still holding the Strip in place, bend a crease at the second bending point in the trim work. You can also use a pencil to further highlight the creases in the Strip.

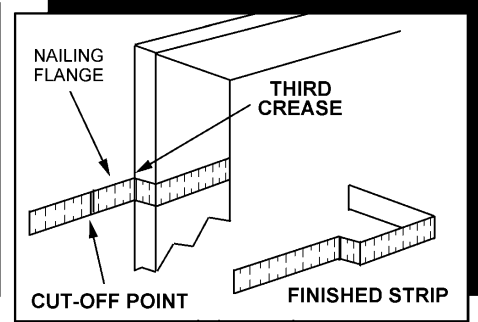

3 Make the third crease at the final bending point in the trim work. You can pull the Strip away from the trim work and hand bend the crease more crisply. Take the Strip and check it against various locations along the trim work to ensure a uniform fit. Using a 2 inch nailing flange (as suggested above), bend a crease in the Strip. That will become the cut-off point indicator.

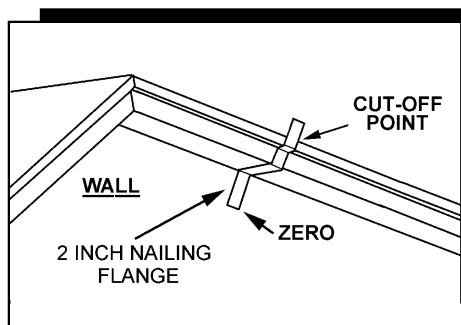

4 As with Steps 1, 2 and 3 above, form the creases into the Pro-Filer Strip at the bending points in the trim work. As with all the Pro-Filer Strip Templates you will come to make, the Strips should not fit too tightly to the trim work. The object is to "float" your trim piece over it.

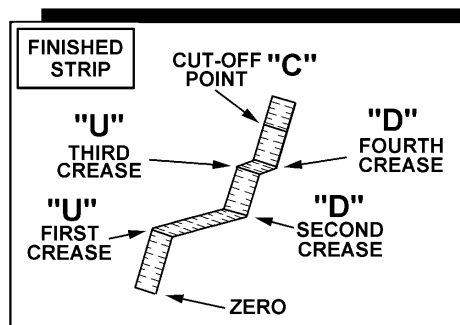

5 As stated above, you can use a pencil to mark the bending information on the Strip. Mark the cut-off point with a "C", mark inward creases with a "U" and outward creases with a "D". See page 3 for detailed information on this step.

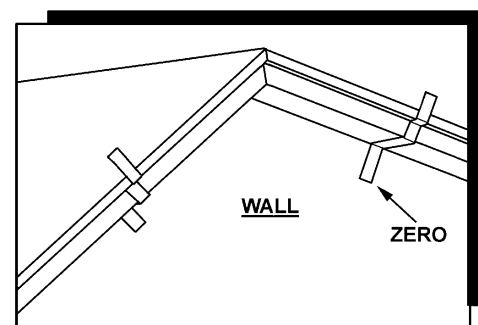

6 To ensure that your finished trim pieces will fit all areas of the trim work, place the Pro-Filer Strip at several points along the trim work. If tightness occurs when fitting the Strip to the trim work, modify the crease (or creases). Slightly and re-check.

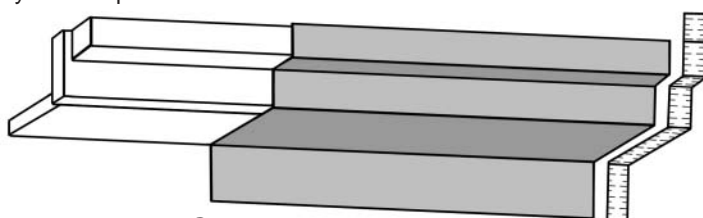

FINISHED TRIM PIECE
NO MEASURING, NO MARKING, NO PROBLEM

Once you familiarize yourself with the Pro-Filer many short-cuts will come to you. For example, the same Pro-Filer strip can be used for repeat trim shapes on all similar windows and strips can be saved for future use or call backs. We recommend practicing with scrap pieces before you begin.

TAPCO PRO-FILER

Shown attached to Port-O-Bender

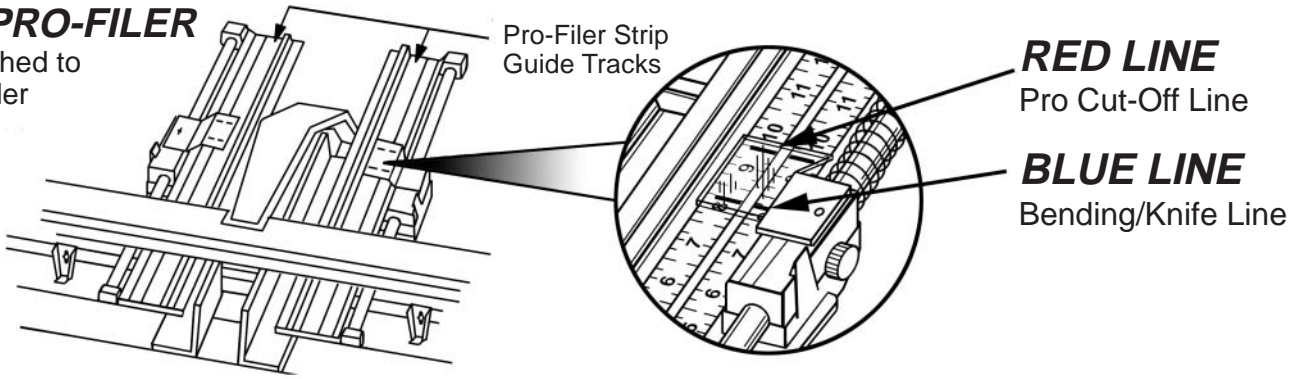

NOTE:

When using the RULED side of the Pro-Filer Strip to represent the FINISH side of the material, the creases which were formed in the strip inward tell you to make this particular bend with the FINISH side up in your bender. As described in Step 2 Making Basic Rake Trim, mark these creases with a "U" (up). With outward creases, place a "D" to indicate FINISH side down when making this bend. Use a "C" to indicate the cut-off point in the material.

Now flatten out the strip with the ruled side facing up. The inward creases, now facing downward, should be marked with a "U" and the outward creases, now facing upward, should be marked with a "D". Proceed to step 1.

USING THE PRO-FILER

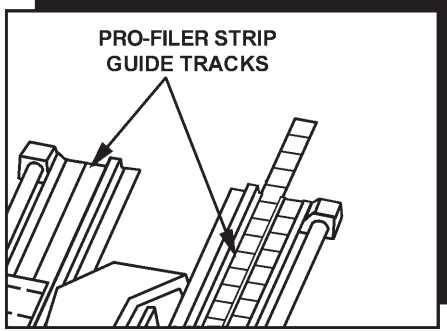

1 Insert Pro-Filer Strip into either of the guide tracks (either track will work). Slide the zero end in first with the ruled side facing up.

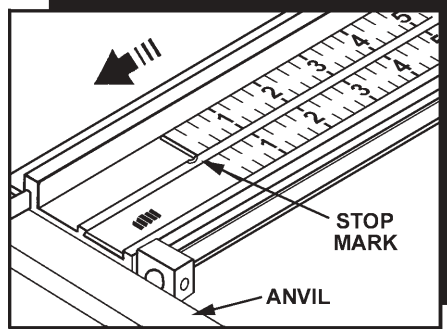

2 Slide strip to stop mark. If properly inserted, strip measurements will correspond with those of the white built-in tape measure. You are now ready to bend material.

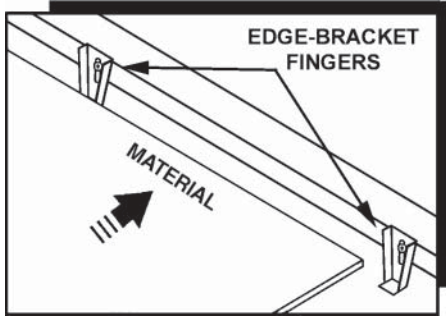

3 Insert material into bender until edge is butted squarely against edge-bracket fingers.

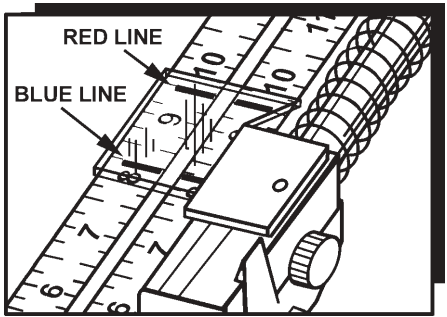

4 Continue inserting material until indicator line reaches the "C" crease in the strip. If using Pro Cut-Off, use the RED LINE. If using a knife, use the BLUE LINE.

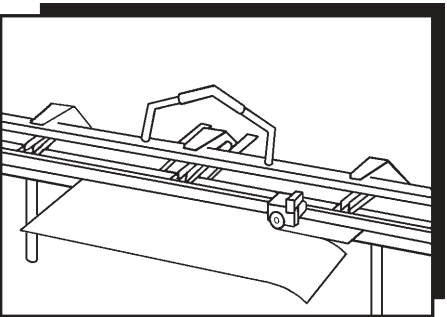

5 USING PRO CUT-OFF With RED LINE at the "C" crease, lock the bender jaws and push Pro Cut-Off along entire length of material.

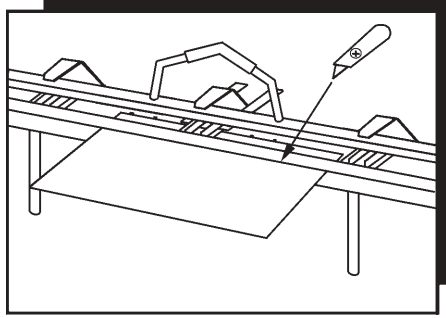

6 USING KNIFE With BLUE LINE at the "C" crease, lock the bender jaws. Score material along stainless bending edge with knife. Bend until material breaks off.

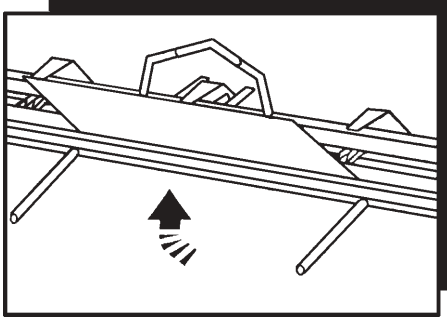

7 On creases marked "U" along the strip, use the BLUE LINE and make bends in the material finish side UP.

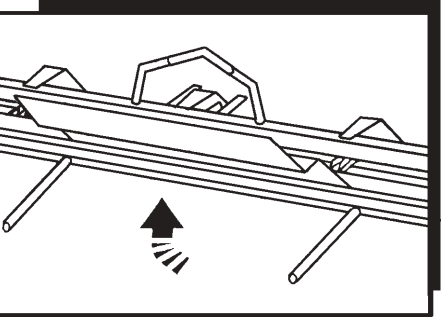

8 On creases marked "D" along the strip, use the BLUE LINE and make bends in the material finish side DOWN.

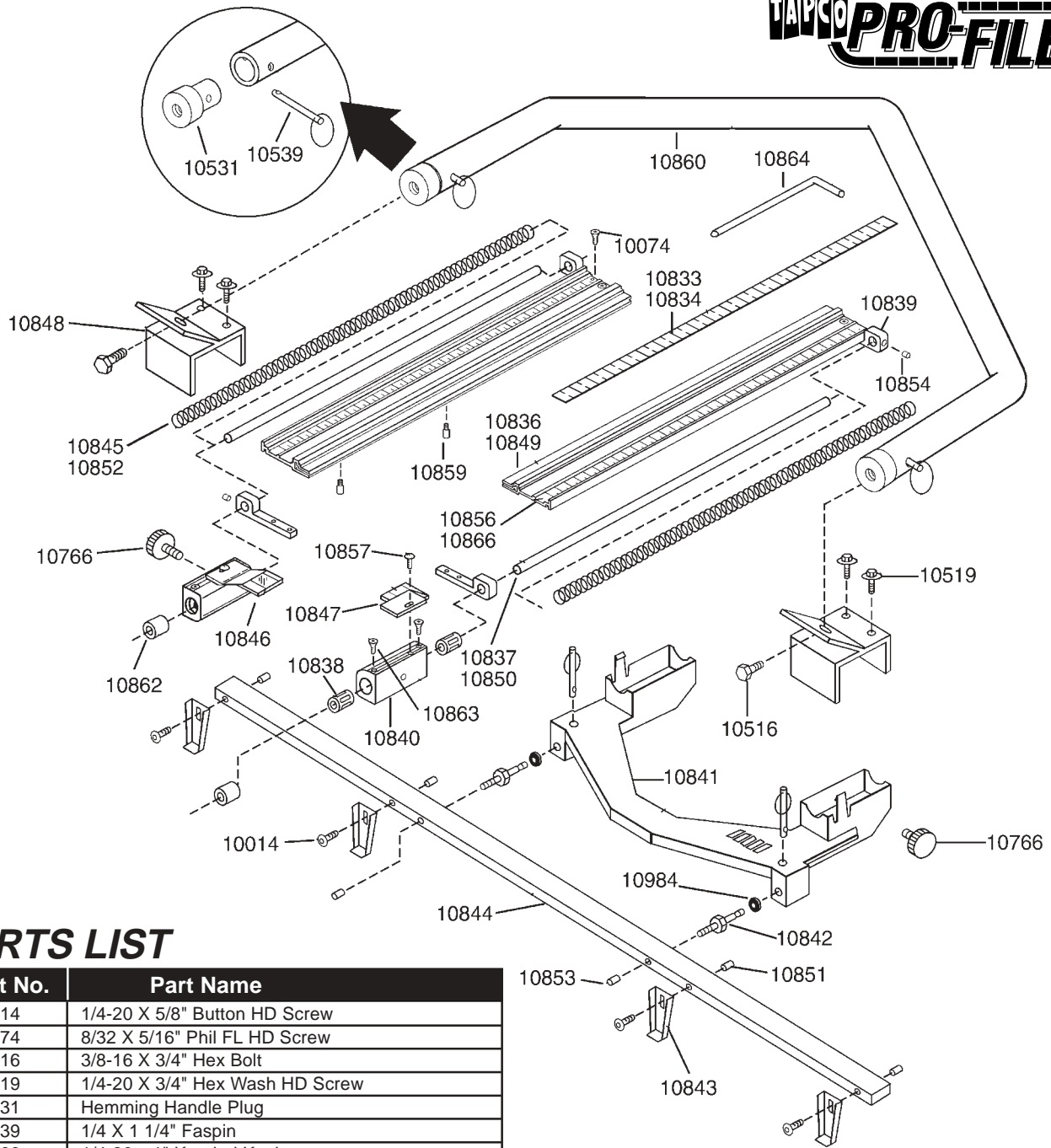

PARTS LIST

Part No.	Part Name
10014	1/4-20 X 5/8" Button HD Screw
10074	8/32 X 5/16" Phil FL HD Screw
10516	3/8-16 X 3/4" Hex Bolt
10519	1/4-20 X 3/4" Hex Wash HD Screw
10531	Hemming Handle Plug
10539	1/4 X 1 1/4" Faspin
10766	1/4-20 x 1" Knurled Knob
10833	Pro-Filer Strips - 14"
10834	Pro-Filer Strips - 19"
10836	Guide Arm - 14"
10837	Guide Rod - '99
10838	Rod Bearing
10839	Rod Bracket
10840	Bearing Housing
10841	Cross Brace
10842	Adjuster Coupling Nut
10843	Edge Bracket Finger
10844	Edge Bracket
10845	Tension Spring - 14"
10846	Guide Lens - Left
10847	Guide Lens - Right
10848	Guard Bracket
10849	Guide Arm - 19"

Part No.	Part Name
10850	Guide Rod - 2000
10851	1/4-20 X 1/2" Set Screw
10852	Tension Spring - 19"
10853	5/16 X 1/4" Set Screw
10854	8/32 X 1/4" Set Screw
10856	Tape Measure - 19"
10857	10-24 X 1/2" Phil Pan HD Screw
10859	Knurled Finger Screw
10860	Hemming Handle Assembly
10862	Bearing Rod Spacer
10863	10/24 X 3/8" Phil FL HD Screw
10864	5/32" Hex Wrench
10866	Tape Measure - 14"
10984	Rubber Grommet

U.S. & Foreign Pats. Pend.